

A B C D E F G H

1  
2  
3  
4  
5  
6

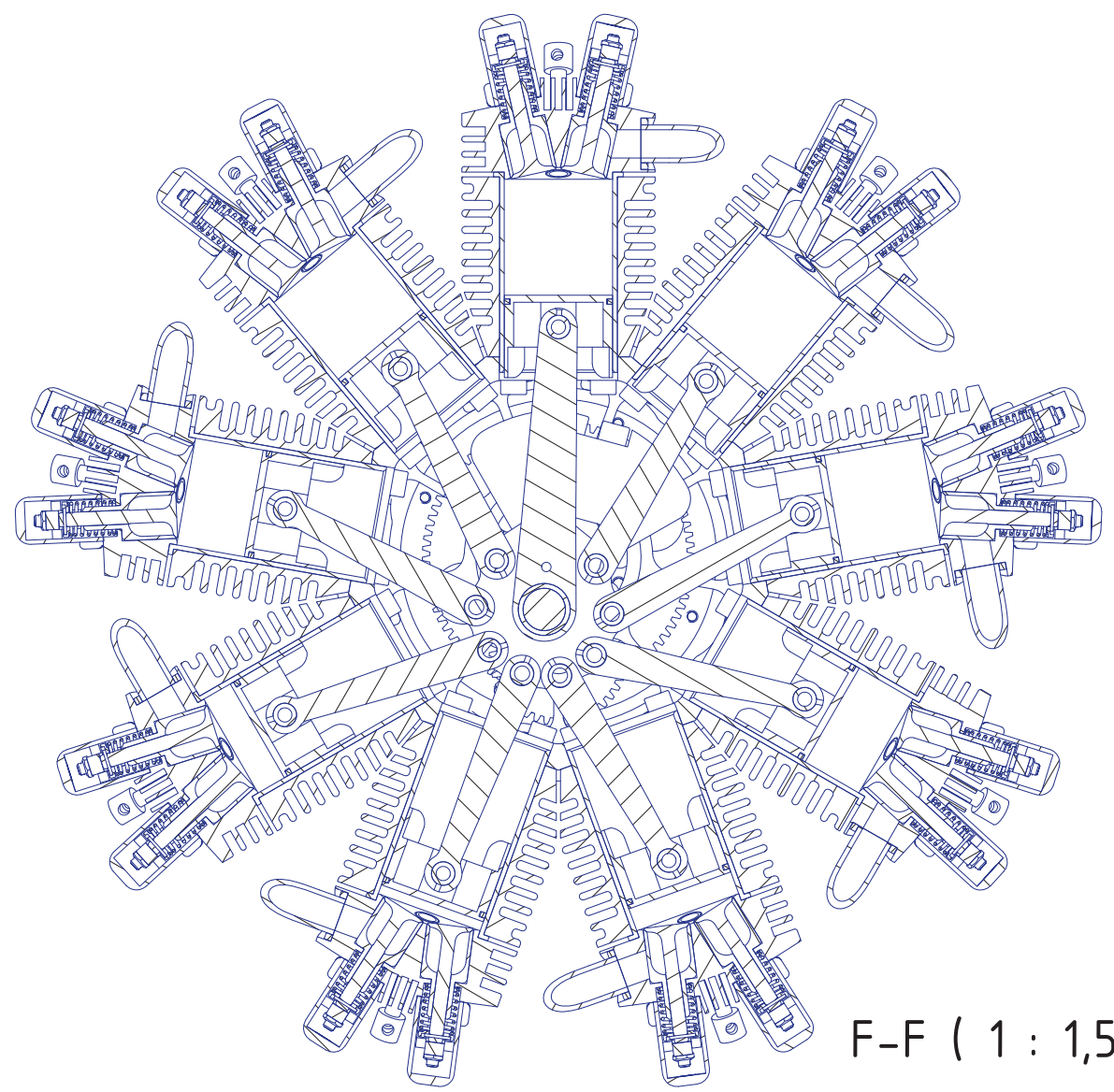
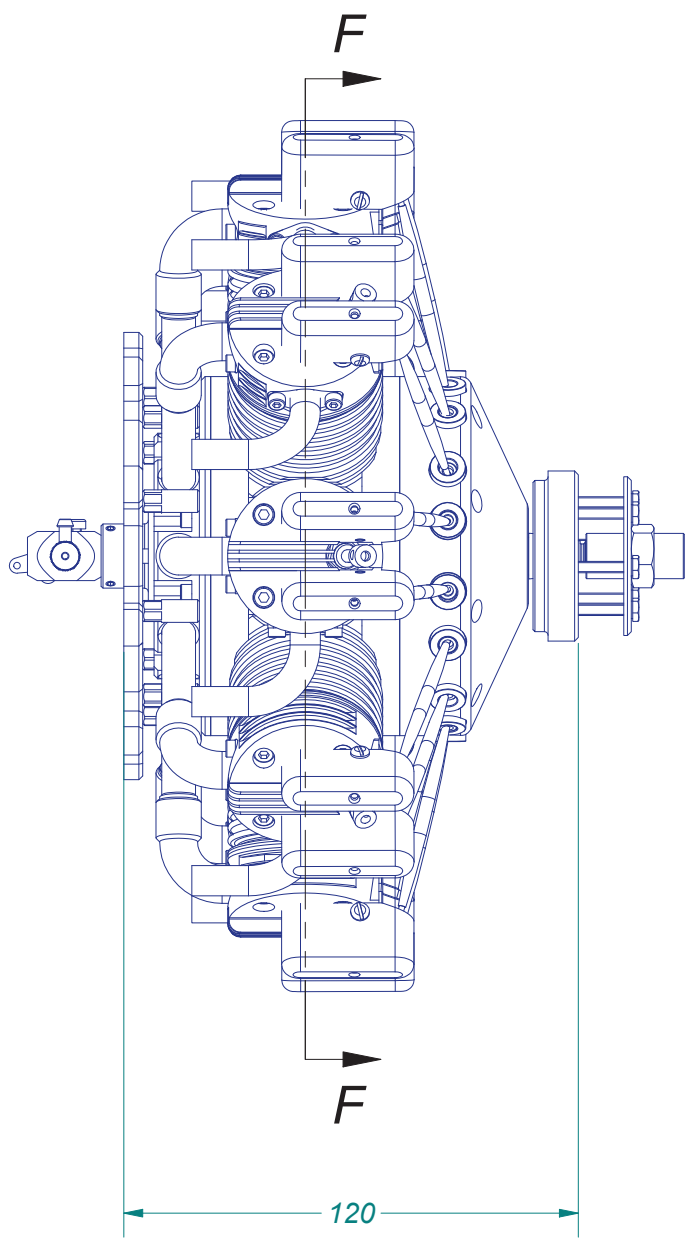

F-F ( 1 : 1,5 )

	Date	Name
Drawn	06.03.2020	Wolfgang
Checked	10.03.2021	as build
Scale	1 : 2	

**WT STERN 2323-R9**

**WT ENGINES**  
www.wtengines.com

Complete Assembly

3  
A4

The information contained in this drawing is the sole property of Wolfgang Trötscher. Any reproduction in part or whole without the written permission of Wolfgang Trötscher is prohibited

A B C D E F G H

1  
2  
3  
4  
5  
6

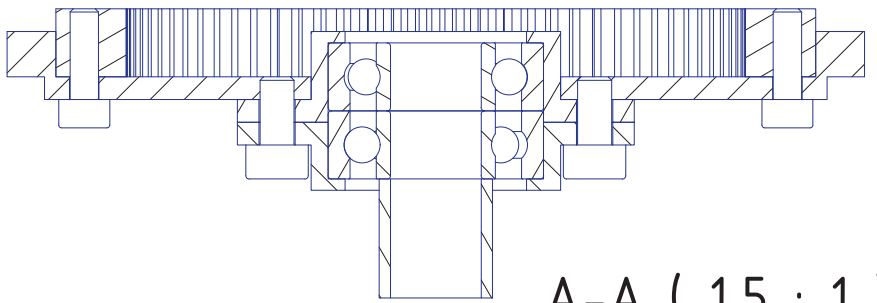
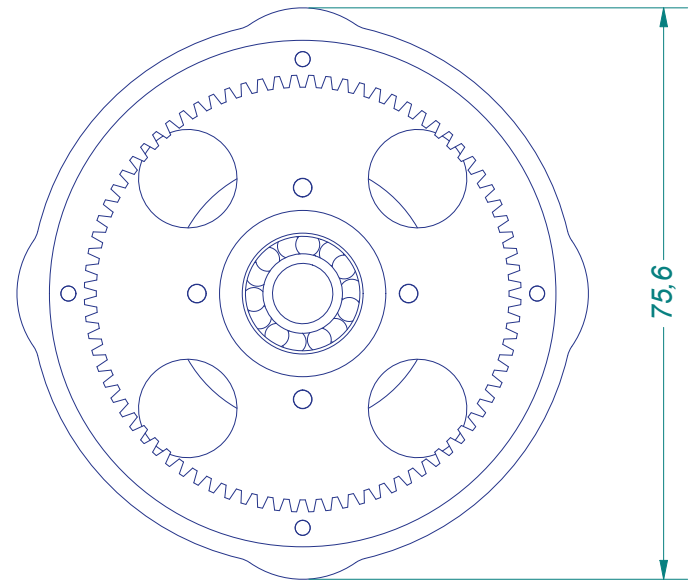
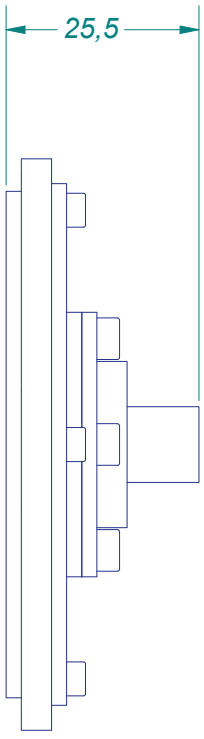
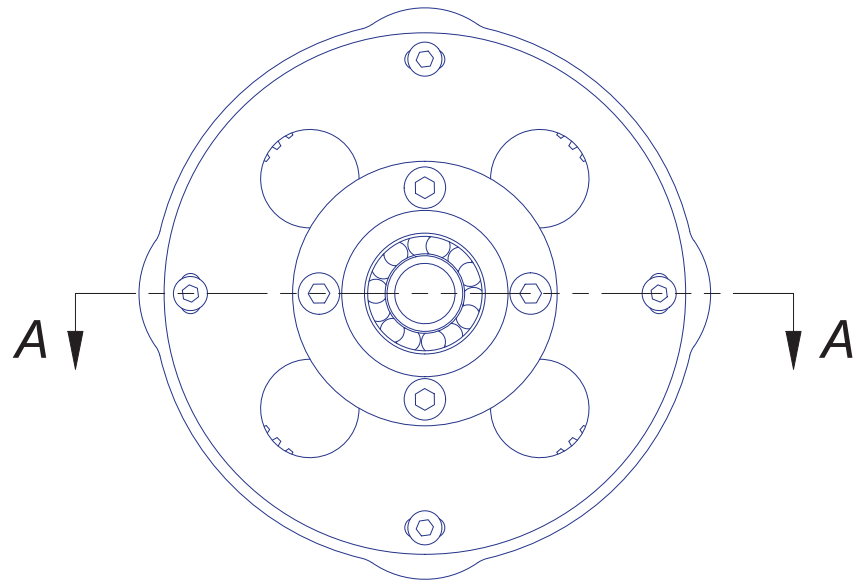

A-A ( 1,5 : 1 )

	Date	Name
Drawn	06.03.2020	Wolfgang
Checked	27.03.2020	as build
Scale	1 : 1	

**WT STERN 2323-R9**

**WT ENGINES**  
www.wtengines.com

Cam disc assembly

3  
A4

The information contained in this drawing is the sole property of Wolfgang Trötscher. Any reproduction in part or whole without the written permission of Wolfgang Trötscher is prohibited

A B C D E F G H

PARTS LIST			
PART NUMBER	DESCRIPTION	MATERIAL	MASS
2323-R9-211	Main bearing shield	Aluminum 6082 T6	45,671 g

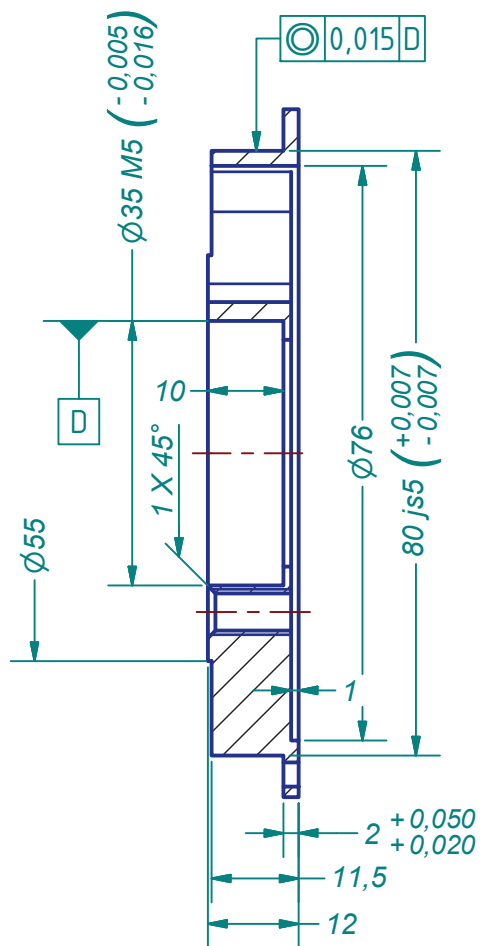
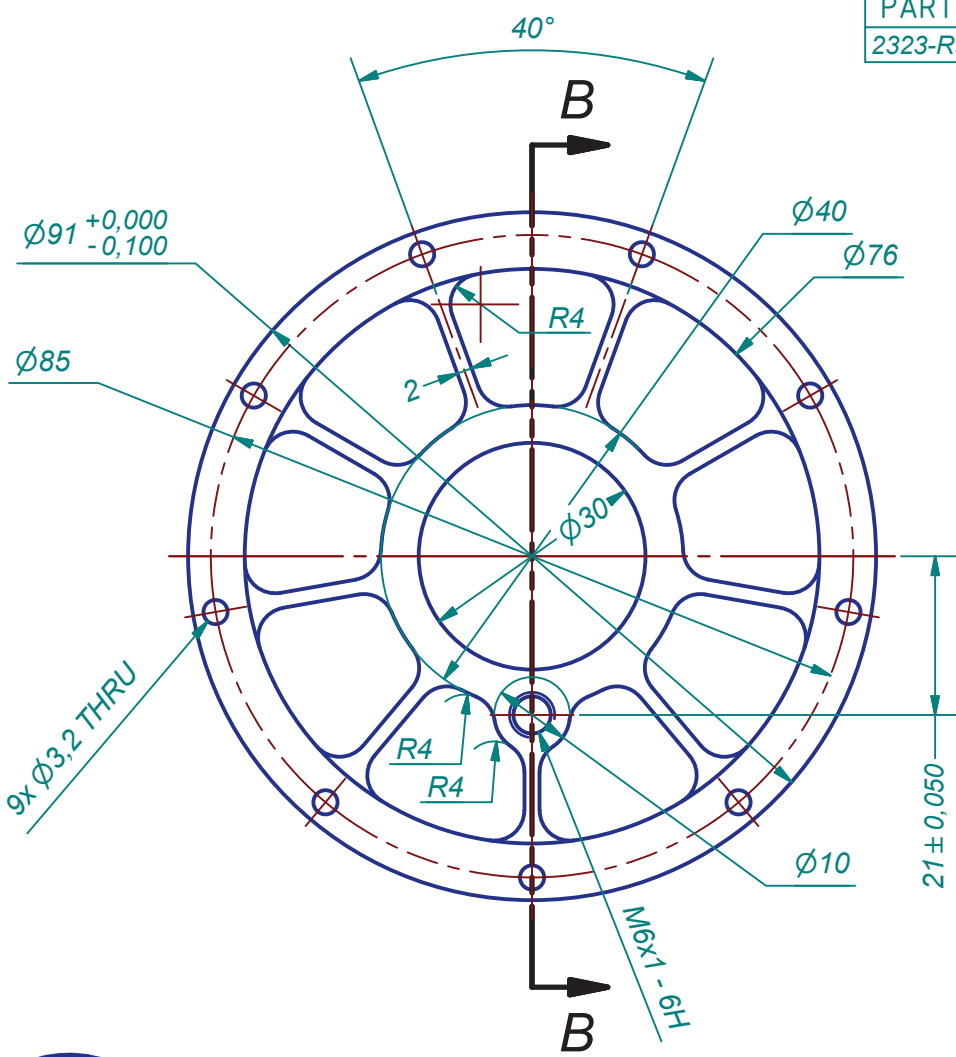

B-B ( 1 : 1 )

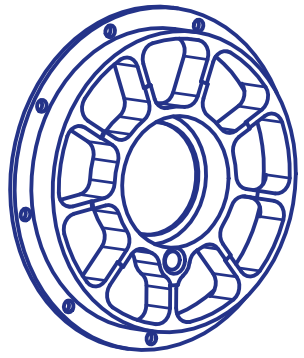

	Date	Name
Drawn	02.03.2020	Wolfgang
Checked	13.03.2020	as build
Scale	1 : 1	

**WT STERN 2323-R9**

**WT ENGINES**  
www.wtengines.com

Main bearing shield

1  
A4

The information contained in this drawing is the sole property of Wolfgang Trötscher. Any reproduction in part or whole without the written permission of Wolfgang Trötscher is prohibited

PARTS LIST			
PART NUMBER	DESCRIPTION	MATERIAL	MASS
2323-R9-403	Valve	Stainless Steel AISI 317	1,863 g

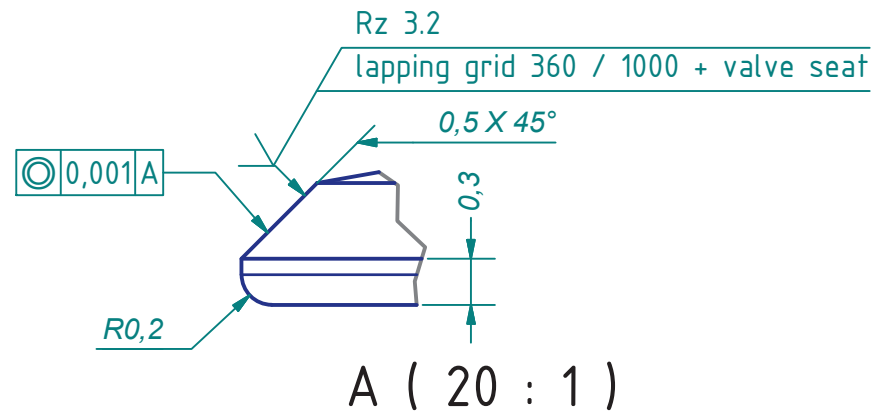
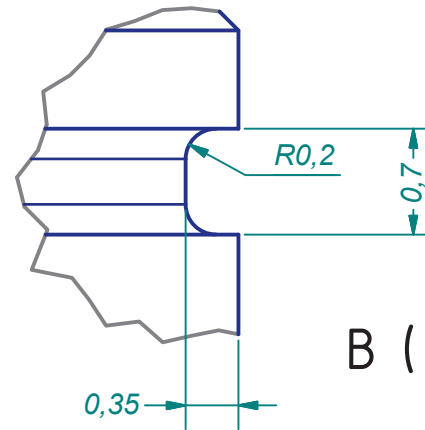
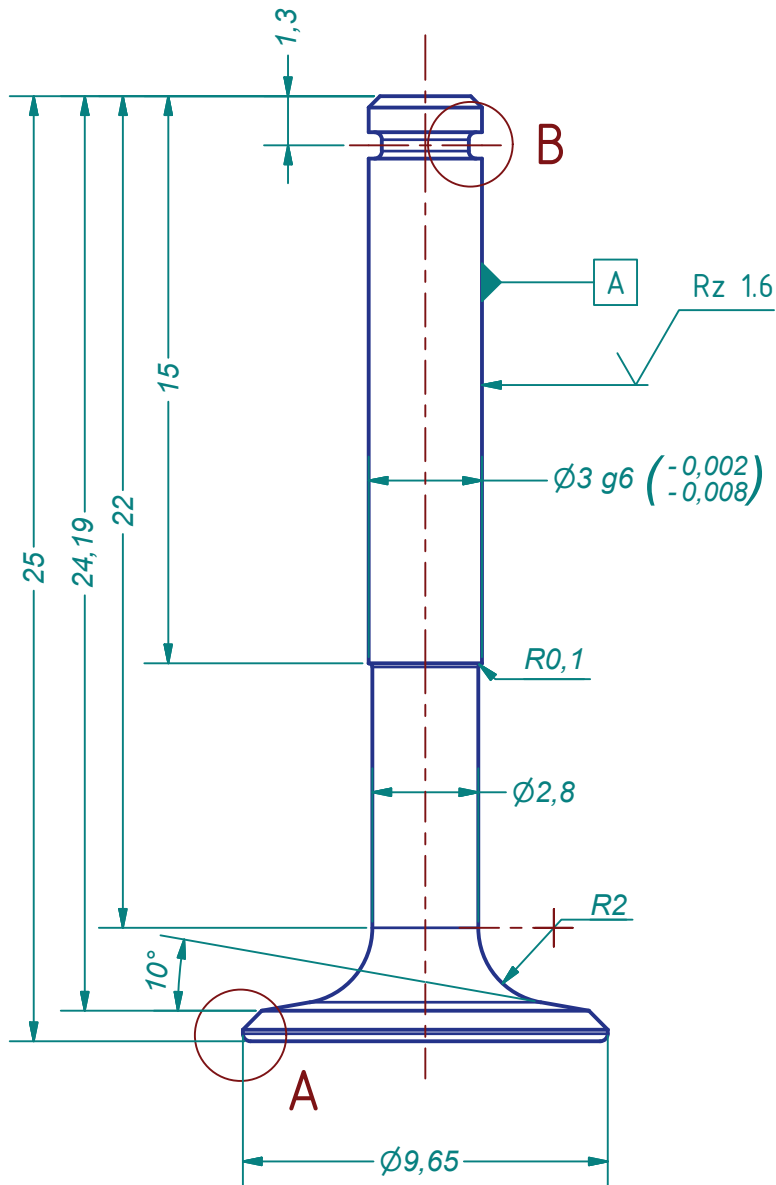

	Date	Name
Drawn	06.01.2019	Wolfgang
Checked	06.02.2021	as build
Scale	5 : 1	

**WT STERN 2323-R9**

**WT ENGINES**  
www.wtengines.com

Valve

1

A4

The information contained in this drawing is the sole property of Wolfgang Trötscher. Any reproduction in part or whole without the written permission of Wolfgang Trötscher is prohibited